

BRVGE1

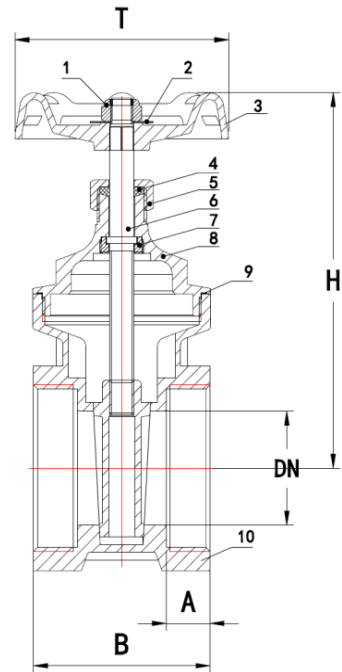

Technical specification:

1. Work medium: Water, Non-corrosive liquid,
Saturated steam.

2. Working temperature: $-20^{\circ}\text{C} \leq t \leq 130^{\circ}\text{C}$

SIZE	DN	A	B	H	T
1/2"	13	11.5	41	72	53
3/4"	15	11.5	45	75	53
1"	19	13	48	85	60
1-1/4"	25	14	54	93	72
1-1/2"	32	15	57	110	72
2"	41	16	65	140	83
2-1/2"	60	22	80	180	96
3"	69	23	87	200	110
4"	88	26	102	235	125

No.	Name	Material
1	Screw	SUS
2	Disc	Al
3	Handle	Steel
4	Seat	PTFE
5	Cap	Brass
6	Stem	Brass
7	Nut	Brass
8	Cap	Brass
9	Seat	PTFE
10	Body	Brass